

Peninsula Booth Approval Form

Deadline: August 31, 2018 – Emailed submissions will not be accepted

All peninsula exhibitors must submit this form with complete scale drawings, both concept and construction, indicating all dimensions including applicable setback requests to RSNA by August 31 for basic approval. Please complete this form and submit with your floor plans indicating conformation to RSNA peninsula booth regulations. See Rule 9C of the RSNA Rules and Regulations for complete peninsula guidelines.

When planning your exhibit for RSNA 2018, keep in mind:

- Only a 10'-wide backwall at the center can be built within a peninsula exhibit.
- No part of the center backwall can exceed a height of 8' from floor of the exhibit hall.
- Hanging signs are not permitted.
- Each 5' side of the backwall cannot exceed the height of 4' as not to block the view or impede the sight lines of neighboring exhibitors.
- Floor covering within the booth is mandatory.

See diagram of peninsula booth layout on the right.

Penalty: Failure to submit Peninsula Booth Approval Form by August 31 may prohibit construction of exhibit.

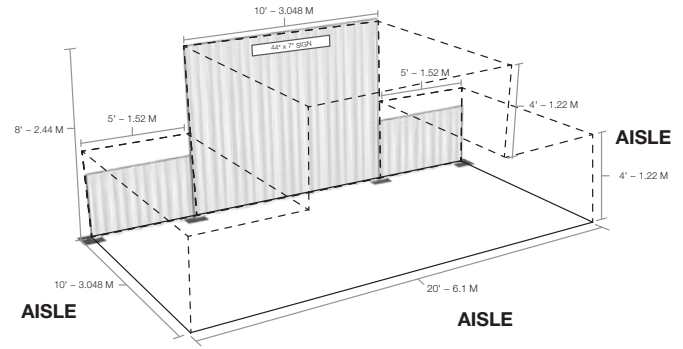

Exhibiting Company Information

Exhibiting Company		Official Contact	
Telephone	Fax	Email Address	
Booth Number	Booth Dimensions	Highest Point of Exhibit (not to exceed 8')	
Booth Contractor	Contact	Telephone	Email Address

I have read, understand and agree to the RSNA Rules and Regulations pertaining to booth design and construction.

Agreed to

X _____
 Signature of Main Exhibit Contact Date

Return this signed form and booth design floor plan to:

Attn: Jorie Dydo
 RSNA Exhibition Services
 820 Jorie Blvd.
 Oak Brook, IL 60523

Deadline: August 31, 2018 Note: Please allow 7-10 business days for processing

Emailed submissions will not be accepted.

For RSNA Use Only – Please do not write in this area

_____ / _____ / _____ Date Received	_____ / _____ / _____ Response to Exhibiting Company
Approved: <input type="radio"/> Yes <input type="radio"/> No	
As noted: _____ _____ _____	
Reviewed by:	
_____ Signature of RSNA Contact	_____ Date

Peninsula Exhibits

The minimum booth size is 10' x 20' with two corners and three open sides thus creating an "end cap." Only a 10' wide backwall can be built within a peninsula exhibit. No part of the backwall may exceed a height of 8' from the floor of the exhibit hall. Each 5' side of the backwall cannot exceed the height of 4' as not to block the view or impede the site lines of neighboring exhibitors.

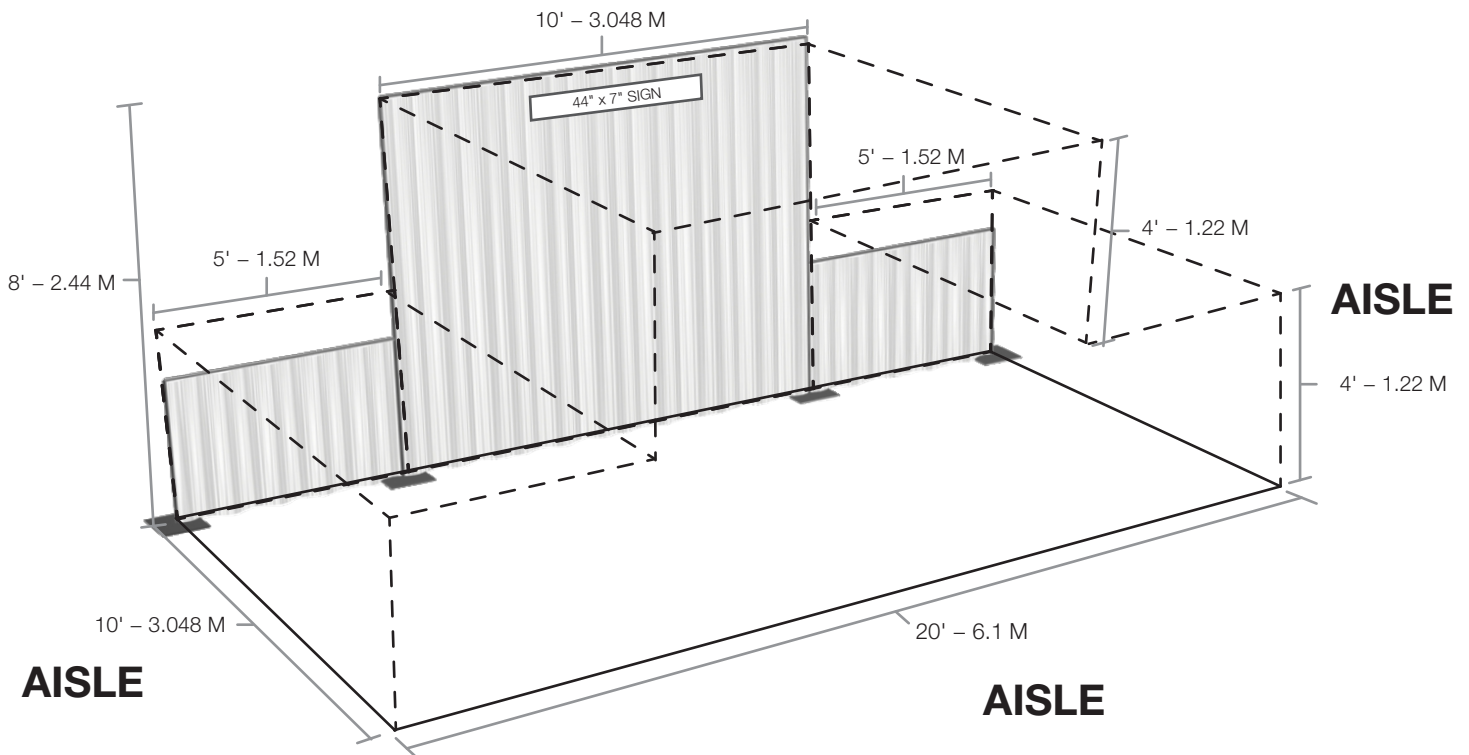

- Exhibitors are required to provide floor coverings for all booths.
- RSNA will set each peninsula booth with 8' high back drape, 3' high side rails and a 44"x7" one-line identification sign.
- Hanging signs are not permitted.