

Peninsula Booth Approval Form

Deadline: September 2, 2016

All Peninsula exhibitors must submit this form with complete scale drawings, both concept and construction, indicating all dimensions including applicable setback requests to RSNA by September 2 for basic approval. Please complete this form and submit with your floor plans indicating conformation to RSNA peninsula booth regulations. See Rule 9C of the RSNA Rules and Regulations for complete peninsula guidelines.

When planning your exhibit for RSNA 2016, keep in mind:

- Only a 10'-wide backwall can be built within a peninsula exhibit.
- No part of the backwall can exceed a height of 8' from floor of the exhibit hall.
- Each 5' side of the backwall cannot exceed the height of 4' as not to block the view or impede the sight lines of neighboring exhibitors.

See diagram of peninsula booth layout on the right.

Penalty: Failure to submit Peninsula Booth Approval Form by September 2 may prohibit construction of exhibit.

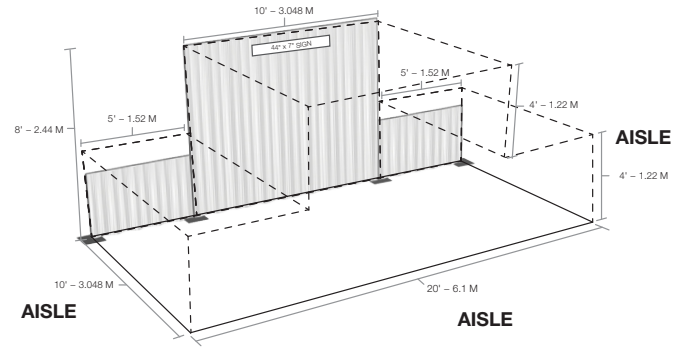

Exhibiting Company Information

Exhibiting Company		Official Contact
Telephone	Fax	Email Address
Booth Number	Booth Dimensions	Highest Point of Exhibit (not to exceed 8')

I have read, understand and agree to the RSNA Rules and Regulations pertaining to booth design and construction.

Agreed to

X _____
Signature of Main Exhibit Contact Date

Return this signed form and booth design floor plan to:

RSNA Technical Exhibits Department
820 Jorie Blvd.
Oak Brook, IL 60523
exhibits@rsna.org

Deadline: September 2, 2016

Note: Please allow 7-10 business days for processing

For RSNA Use Only – Please do not write in this area	
_____/_____/_____ Date Received	_____/_____/_____ Response to Exhibiting Company
Approved:	<input type="radio"/> Yes <input type="radio"/> No
As noted:	_____
Reviewed by:	X _____
Signature of RSNA Contact	Date